

CPSC 121,  
2005/6 Winter Term 2, Section 203  
Quiz 1

Name: SOLUTION

Student ID: \_\_\_\_\_

Signature: \_\_\_\_\_

- You have **25 minutes** to write the **4 questions** on this examination.
- A total of 40 marks are available. Each question is worth 10 marks. **You may want to complete what you consider to be the easiest questions first!**
- Justify all of your answers.
- No notes or electronic equipment are allowed.
- Keep your answers short. If you run out of space for a question, you have written too much.
- The number in square brackets to the left of the question number indicates the number of marks allocated to that question.
- Use the attached blank page for your rough work.
- Good luck!

Question	Marks
1	
2	
3	
4	
Total	

UNIVERSITY REGULATIONS:

- Each candidate should be prepared to produce, upon request, his/her university-issued ID.
- No candidate shall be permitted to enter the examination room after the expiration of one half hour or to leave during the first half hour of the examination.
- CAUTION: candidates guilty of any of the following, or similar, dishonest practices shall be immediately dismissed from the examination and shall be liable to disciplinary action.
  1. Having at the place of writing, or making use of, any books, papers or memoranda, electronic equipment, or other memory aid or communication devices, other than those authorised by the examiners.
  2. Speaking or communicating with other candidates.
  3. Purposely exposing written papers to the view of other candidates. The plea of accident or forgetfulness shall not be received.
- Candidates must not destroy or mutilate any examination material; must hand in all examination papers; and must not take any examination material from the examination room without permission of the invigilator.

[10] 1. The table below contains propositions and logic circuits. We say two entries are correctly matched if two propositions (or the two circuits, or the proposition and the circuit) are logically equivalent. The table contains three pairs of matching table entries.

- List the three pairs of matched entries (for instance “A with B, C with D, E with F”).
- Then prove that the two entries in one matched pair are logically equivalent, using a truth table.
- Finally prove that the two entries in another matched pair are logically equivalent, using the equivalence laws discussed in class. You do not have to write the name of each law you are applying, but you must apply **exactly one law at a time**.

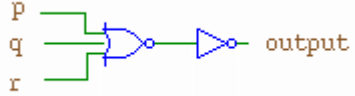
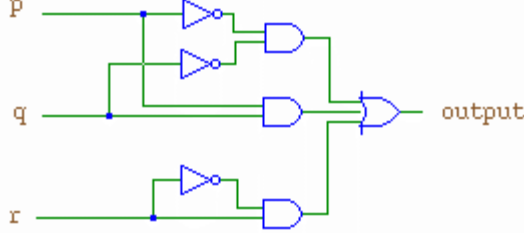
A. $p \vee q \vee r$	D. $\sim(p \oplus q)$
B. 	E. 
C. $r \rightarrow (p \leftrightarrow q)$	F. $(\sim p \vee q \vee \sim r) \wedge (p \vee \sim q \vee \sim r)$

A with B, C with F, D with E

$$p \vee q \vee r \equiv \sim\sim(p \vee q \vee r)$$

$$r \rightarrow (p \leftrightarrow q) \equiv \sim r \vee (p \leftrightarrow q)$$

$$\equiv \sim r \vee (p \rightarrow q \wedge q \rightarrow p)$$

$$\equiv \sim r \vee ((\sim p \vee q) \wedge (\sim q \vee p))$$

$$\equiv (\sim r \vee \sim p \vee q) \wedge (\sim r \vee \sim q \vee p)$$

$$\equiv (\sim p \vee q \vee \sim r) \wedge (p \vee \sim q \vee \sim r)$$

$$(\sim p \wedge \sim q) \vee (p \wedge q) \vee (r \wedge \sim r) \equiv (\sim p \wedge \sim q) \vee (p \wedge q) \vee F$$

$$\equiv (\sim p \wedge \sim q) \vee (p \wedge q)$$

$$\equiv \sim(\sim(\sim p \wedge \sim q) \wedge \sim(p \wedge q))$$

$$\equiv \sim((p \vee q) \wedge \sim(p \wedge q))$$

$$\equiv \sim(p \text{ XOR } q)$$

Truth tables omitted, but note that the table for  $\sim(p \text{ XOR } q) \equiv (\sim p \wedge \sim q) \vee (p \wedge q) \vee (r \wedge \sim r)$  **should** include a column for  $r$  and should have 8 rows. It's correct in general to prove this by pointing out that  $(r \wedge \sim r) \equiv F$ , and drop the disjunct, but the problem asks for a proof just using truth tables.

[10] 2. Prove the following theorem. For each step of the proof, indicate which numbered propositions you are using and the name of the inference rule or logical equivalence you used. Some of the rules of inference and of equivalence are provided for your reference.

- (1)  $t$
- (2)  $t \rightarrow \sim p \wedge s$
- (3)  $\sim r \vee p$
- (4)  $w \vee \sim q$
- (5)  $\underline{q \rightarrow r \wedge s}$   
 $\therefore, \sim q$

- (6)  $\sim p \wedge s$  by 1, 2, MP
- (7)  $\sim p$  by 6, simp
- (8)  $\sim r$  by 3, 7, DS
- (9)  $\sim r \vee \sim s$  by 8, add
- (10)  $\sim(r \wedge s)$  by 9, DeM
- (11)  $\sim q$  by 5, 10, MT

QED

Rule of inference	Name
$\underline{p}$ $\therefore p \vee q$	Addition
$\underline{p \wedge q}$ $\therefore p$	Simplification
$\underline{p}$ $\underline{p \rightarrow q}$ $\therefore q$	Modus ponens
$\underline{\sim q}$ $\underline{p \rightarrow q}$ $\therefore \sim p$	Modus tollens
$\underline{p \rightarrow q}$ $\underline{q \rightarrow r}$ $\therefore p \rightarrow r$	Hypothetical syllogism
$\underline{p \vee q}$ $\underline{\sim p}$ $\therefore q$	Disjunctive syllogism

Law Name	Equivalences
Identity	$p \wedge T \equiv p$ $p \vee F \equiv p$
Domination	$p \wedge F \equiv F$ $p \vee T \equiv T$
Distributive	$p \wedge (q \vee r) \equiv (p \wedge q) \vee (p \wedge r)$ $p \vee (q \wedge r) \equiv (p \vee q) \wedge (p \vee r)$
Absorbtion	$p \vee (p \wedge q) \equiv p$ $p \wedge (p \vee q) \equiv p$
Negation	$p \wedge \sim p \equiv F$ $p \vee \sim p \equiv T$
De Morgan's	$\sim(p \wedge q) \equiv (\sim p) \vee (\sim q)$ $\sim(p \vee q) \equiv (\sim p) \wedge (\sim q)$

[10] 3. Express the following in predicate logic:

All people can be fooled about some things, and somebody can be fooled about everything, but not everybody can be fooled about everything.

Be sure to define any new predicate(s) you use!

$F(x, y)$  means  $x$  can be fooled about  $y$ , where  $x$ 's domain is the set of all people  $P$ , and  $y$ 's domain is the set of all things  $T$ .

$$\begin{aligned} & (\forall x \in P, \exists y \in T, F(x, y)) \wedge \\ & (\exists x \in P, \forall y \in T, F(x, y)) \wedge \\ & \sim (\forall x \in P, \forall y \in T, F(x, y)) \end{aligned}$$

[10] 4. For the following parts, let the predicate  $V(x, y)$  mean  $x$  divides  $y$ , where  $x$  and  $y$  are elements of the natural numbers,  $\mathbb{N}$ .

[7] a. Express the following predicate logic statement as a clear, brief English statement. (Note: there is a brief way to state this.)

$$\begin{aligned} & \forall n \in \mathbb{N}, n > 1 \rightarrow \\ & ( (\sim \exists d \in \mathbb{N}, V(d, n) \wedge 1 < d \wedge d < n) \vee \\ & V(2, n) ) \end{aligned}$$

Long version: for all natural numbers  $n$ , if  $n$  is greater than one, then either there's some number between 1 and  $n$  that divides  $n$  or 2 divides  $n$ .

Short version: every natural number greater than one is either prime or even.

[3] b. The predicate logic statement from part (a) is false. Prove that it is false. Your proof should be brief and in English, rather than in logic.

9 is divisible by 3; so, it is a natural number greater than 1 that is neither prime nor even.