

THE UNIVERSITY OF BRITISH COLUMBIA
CPSC 121: MIDTERM 2 – Individual – March 12, 2014

Important notes about this examination

1. **You have 65 minutes to complete this exam.**
2. No electronic aides (e.g., phones or calculators) are allowed in the exam.
3. Each student may bring up to three 8.5x11" sheets of paper with any information of the student's choice on them, typed or printed, one side or both, although the sheets must be readable without magnification!
4. Please see the regulations regarding student conduct during examinations on the opposite side of this page!
5. Good luck!

Full Name: _____

Signature: _____

UBC Student #: _____

Please do not write in this space:

Question 1: _____ Question 4: _____

Question 2: _____ Question 5: _____

Question 3: _____



3 236351 870758

Student Conduct during Examinations

1. Each examination candidate must be prepared to produce, upon the request of the invigilator or examiner, his or her UBCcard for identification.
2. No questions will be answered in this exam. If you see text you feel is ambiguous, make a reasonable assumption, write it down, and proceed to answer the question.
3. No examination candidate shall be permitted to enter the examination room after the expiration of one-half hour from the scheduled starting time, or to leave during the first half hour of the examination. Should the examination run forty-five (45) minutes or less, no examination candidate shall be permitted to enter the examination room once the examination has begun.
4. Examination candidates must conduct themselves honestly and in accordance with established rules for a given examination, which will be articulated by the examiner or invigilator prior to the examination commencing. Should dishonest behaviour be observed by the examiner(s) or invigilator(s), pleas of accident or forgetfulness shall not be received.
5. Examination candidates suspected of any of the following, or any other similar practices, may be immediately dismissed from the examination by the examiner/invigilator, and may be subject to disciplinary action:
 - i. speaking or communicating with other examination candidates, unless otherwise authorized;
 - ii. purposely exposing written papers to the view of other examination candidates or imaging devices;
 - iii. purposely viewing the written papers of other examination candidates;
 - iv. using or having visible at the place of writing any books, papers or other memory aid devices other than those authorized by the examiner(s); and,
 - v. using or operating electronic devices including but not limited to telephones, calculators, computers, or similar devices other than those authorized by the examiner(s)— (electronic devices other than those authorized by the examiner(s) must be completely powered down if present at the place of writing).
6. Examination candidates must not destroy or damage any examination material, must hand in all examination papers, and must not take any examination material from the examination room without permission of the examiner or invigilator.
7. Notwithstanding the above, for any mode of examination that does not fall into the traditional, paper-based method, examination candidates shall adhere to any special rules for conduct as established and articulated by the examiner.
8. Examination candidates must follow any additional examination rules or directions communicated by the examiner(s) or invigilator(s).

This page left intentionally (almost) blank.

If you write answers here (or anywhere other than their intended location), mark them clearly, indicate which question they respond to, and indicate at the provided solution blank for that question where you wrote your solution.

[15] 1. **iSaks:** At the iSaks auction site, vendors offer up “lots” of identical items for sale. Each lot must have at least 1000 items. A bid is a dollar value **per item** d and a quantity q of items: (d, q) .

The following definitions describe this domain, but unless we state them explicitly, the parts described as “intentions” are not known to hold.

- B is the set of bidders
- $\text{Lot}(i, n)$ means lot number i offers n (a positive integer) items for auction. i is a positive integer ID number. (The intention of i is that it uniquely identifies a particular lot and tells us what order lots were offered in; that is, no two lots should have the same ID number. For now, iSaks sells only lots of salt shakers; so, there’s no need for a description of the item.)
- $\text{Bid}(j, b, d, q, i)$ means bidder b bid d (positive integer) dollars per item for q (positive integer) items on the lot with ID i . j is a positive integer ID number for the bid. (A lot and a bid may coincidentally have the same ID number, but the intention is that no two bids should have the same ID number.)
- $\text{Won}(b, d, q, i)$ means that bidder b won q items from lot i at the price d .

[6] a. **Defining Predicates:**

i. It would be handy to be able to refer to a bidder’s “final bid”. Define the predicate $\text{FBid}(b, d, q, i)$ to mean that the highest (by ID number) bid by bidder b on lot i is for d dollars per item and q items.
 $\text{FBid}(b, d, q, i) \equiv$

ii. Define a predicate $\text{Winner}(b, i)$ to mean that bidder b won lot i (for some dollar value and quantity).
 $\text{Winner}(b, i) \equiv$

[7] b. **Making Statements:**

State the following facts that we want to assume true in predicate logic. **YOU MAY USE THE EXTRA PREDICATES YOU WERE ASKED TO DEFINE ABOVE.**
(Assume they are correct.)

i. Each lot must have at least 1000 items.

ii. The final bid of a winning bidder on a lot is never for less money than the final bid of a losing bidder on the same lot.

[2] c. **Negation practice:**

Negate the following statement, moving the negations “inward” as far as they will go:

$$\forall i \in \mathbf{Z}^+, \forall b_1 \in B, \text{Winner}(b_1, i) \rightarrow \sim \exists b_2 \in B, \text{Winner}(b_2, i) \wedge b_1 \neq b_2.$$

[8] 2. **Who's on First (or the Equivalent)?**

For each of the following pairs of predicate logic statements, **CIRCLE ONE OF: EQUIV** (meaning they're logically equivalent), $1 \rightarrow 2$ (meaning the second one follows from the first but the first does not follow from the second), $2 \rightarrow 1$ (meaning the first one follows from the second but the second one does not follow from the first), or **NEITHER** meaning neither one implies the other.

- (a) $\exists x \in X, R(x).$
 $\forall x \in X, \sim R(x).$

EQUIV $1 \rightarrow 2$ $2 \rightarrow 1$ **NEITHER**

- (b) $\exists x \in X, \exists y \in X, P(x, y) \rightarrow Q(x, y).$
 $\exists y \in X, \exists x \in X, \sim Q(x, y) \rightarrow \sim P(x, y).$

EQUIV $1 \rightarrow 2$ $2 \rightarrow 1$ **NEITHER**

- (c) $\forall x \in X, P(x) \wedge \sim \exists y \in Y, Q(x, y).$
 $\forall x \in X, \forall y \in Y, \sim Q(x, y).$

EQUIV $1 \rightarrow 2$ $2 \rightarrow 1$ **NEITHER**

- (d) $\sim \exists x \in X, \sim \exists y \in Y, \sim \exists z \in Z, P(x, y) \wedge P(y, z).$
 $\forall x \in X, \exists y \in Y, \forall z \in Z, P(y, z) \rightarrow \sim P(x, y).$

EQUIV $1 \rightarrow 2$ $2 \rightarrow 1$ **NEITHER**

[11] 3. **Sketchy Proofs:**

[6] a. **Pred Logic Statement to Proof:**

Sketch a proof in as much detail as possible for the theorem:

Theorem: $\forall x \in X, (\sim P(x, x) \vee (\forall y \in Y, P(x, y))) \rightarrow \exists z \in Z, Q(x, z) \vee Q(z, x)$.

(Do not use logical equivalences to alter the form of the theorem, which also means no proof by contradiction or contrapositive.)

NOTE: if your proof includes choosing a witness value, let us know which other variables' values its value can be based on.

[5] b. **Proof to English Theorem:**

Consider the following fragment of a proof which is missing some details. (It was damaged during an ill-fated forest hike by algorithmicist R. R. Hood.) Write the theorem this was proving in predicate logic in as much detail as possible. Clearly define any sets or predicates you need.

Proof: Without loss of generality, let n be a non-negative integer (specifically a number of keys). We design the following “binomial queue” f of our choice: ...

SECTION OF PROOF LOST IN WOLF ATTACK ...

Note that this binomial queue has exactly n nodes.

Without loss of generality, let g be a *different* binomial queue. We now show that g has some number of keys m that is not equal to n .

[12] 4. **I Want the PROOF:**

Prove the following theorems using informal, English-language proofs. **Substantial partial credit** is available for well-formed proofs. Unclear, awkward, or unusual proof structures that are not precisely correct are likely to lose substantial credit.

[7] a. Prove the following theorem:

$$\forall x \in X, (P(x, x) \vee (\forall y \in X, Q(x, y))) \rightarrow \exists z \in X, P(z, z) \vee Q(x, z).$$

[5] b. We first give an example to illustrate some terms: The binary number 1001011 has four 1 bits in it. If we add 1 to it, we get 1001100, which has one fewer 1 bits than the original value.

Now, prove the following theorem: Adding 1 to an unsigned binary integer with b bits cannot decrease the number of 1 bits in that number by more than b nor increase the number of 1 bits by more than 1.

[4] 5. **Manifold Circuits:**

Consider the following diagram of an arithmetic logic unit (ALU) from lab.

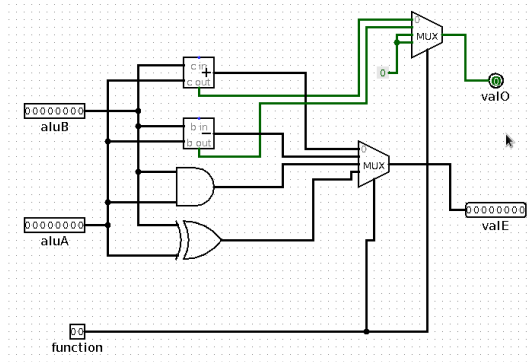

The image contains two simple gates (AND and XOR), an addition module, a subtraction module, and two multiplexers. The two modules and the multiplexers are critical to the functioning of the ALU.

[2] a. Can the modules and the multiplexers be built from simple gates such as AND, OR, and NOT? **Briefly** justify your answer.

[2] b. Briefly explain why the following statement is incorrect: “The valO output is only usable for function values of 0 and 1 because the MUX in the upper-right only has actual inputs for function values of 0 and 1.”

This page left intentionally (almost) blank.

If you write answers here (or anywhere other than their intended location), mark them clearly, indicate which question they respond to, and indicate at the provided solution blank for that question where you wrote your solution.

This page left intentionally (almost) blank.

If you write answers here (or anywhere other than their intended location), mark them clearly, indicate which question they respond to, and indicate at the provided solution blank for that question where you wrote your solution.