

CPSC 121 Sample Final Examination  
December 2008

Name: \_\_\_\_\_ Student ID: \_\_\_\_\_  
Signature: \_\_\_\_\_

- You have 150 minutes to write the 8 questions on this examination. A total of 100 marks are available.
- **Justify all of your answers.**
- You are allowed to bring in one hand-written, double-sided 8.5 x 11 sheet of notes, and nothing else.
- Keep your answers short. If you run out of space for a question, you have written too much.
- The number in square brackets to the left of the question number indicates the number of marks allocated for that question. Use these to help you determine how much time you should spend on each question.
- Use the back of the pages for your rough work.
- **Good luck!**

Question	Marks
1	
2	
3	
4	
5	
6	
7	
8	
Total	

UNIVERSITY REGULATIONS:

- Each candidate should be prepared to produce, upon request, his/her library card.
- No candidate shall be permitted to enter the examination room after the expiration of one half hour, or to leave during the first half hour of the examination.
- CAUTION: candidates guilty of any of the following, or similar, dishonest practices shall be immediately dismissed from the examination and shall be liable to disciplinary action.
  1. Having at the place of writing, or making use of, any books, papers or memoranda, electronic equipment, or other memory aid or communication devices, other than those authorised by the examiners.
  2. Speaking or communicating with other candidates.
  3. Purposely exposing written papers to the view of other candidates. The plea of accident or forgetfulness shall not be received.
- Candidates must not destroy or mutilate any examination material; must hand in all examination papers; and must not take any examination material from the examination room without permission of the invigilator.

- [16] 1. { **Medium-Easy** } Consider the following two columns containing logical expressions, set expressions, and circuits. Each element of the first column is equivalent to an element of the second column. For each element of the first column, write down the element of the second column that it is equivalent to, and give a short proof to justify your choice.

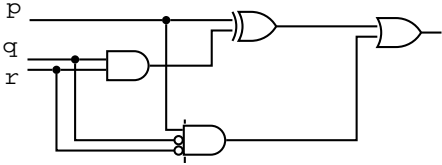
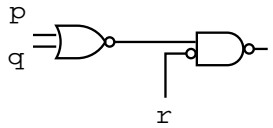
<p>A. <math>(P \Delta Q) \cup R</math></p>	<p>1. <math>p \oplus (q \wedge r)</math></p>
<p>B. <math>p \vee q \vee r</math></p>	<p>2. <math>r \vee (\sim q \rightarrow \sim p)</math></p>
<p>C.</p> 	<p>3.</p> 
<p>D. <math>(p \rightarrow q) \vee \sim p \vee r</math></p>	<p>4. <math>(P \cup Q \cup R) - (P \cap Q \cap R^C)</math></p>

- [15] 2. { **Medium-Hard** } Let  $\mathcal{U}$  be a set, and  $\mathcal{P}(\mathcal{U})$  denote its power set. For each subset  $A$  of  $\mathcal{U}$ , we can define a function  $f_A : \mathcal{P}(\mathcal{U}) \rightarrow \mathcal{P}(\mathcal{U})$  by

$$f_A(S) = A - S$$

Prove that  $f_A$  is one-to-one if and only if  $A = \mathcal{U}$ .

[10] 3. { **Medium-Easy** } Prove that for any positive integer  $n$

$$\sum_{i=0}^n \frac{1}{i!} \leq 3 - \frac{1}{n}$$

Recall that  $0! = 1$ , and for  $n > 0$ ,  $n! = 1 * 2 * 3 * \cdots * n$ . If you want, you can use the fact that for every  $n \geq 1$

$$\frac{1}{(n+1)!} \leq \frac{1}{n(n+1)}$$

without proving it.

[10] 4. { **Medium** } Let  $p_0, p_1, p_2, p_3, \dots$  be an integer sequence defined by

$$p_0 = 1, p_1 = 2, p_2 = 3, \quad \text{and}$$
$$p_n = p_{n-1} + p_{n-2} + p_{n-3} \quad \text{for all } n \in \mathbf{Z}^+ \text{ where } n \geq 3.$$

(For example,  $p_3 = 3 + 2 + 1 = 6$  and  $p_4 = 6 + 3 + 2 = 11$ .)  
Prove that for all nonnegative integers  $n$ ,  $p_n \leq 3^n$ .

[24] 5. { **Hard** } Figure 1 shows a sequential logic circuit (i.e. one with state held in D flip-flops). The circuit has inputs *up* and *down* and outputs  $q_0$  and  $q_1$ . We will refer to the outputs combined together as  $q$  and interpret  $q$  as a two's complement, binary value.

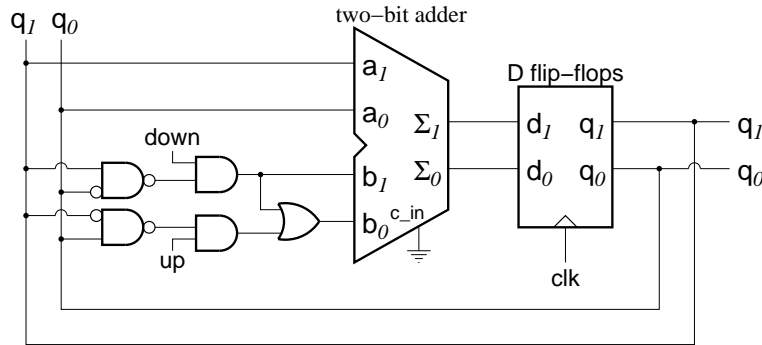

Figure 1: Sequential circuit for question 5

[6] a. Complete the table below as follows:

- For the column labeled  $q$ , write the value of  $q$  interpreted as a two's complement binary integer.
- Let us call  $b_1$  and  $b_0$  the two bits of the lower input to the adder in the circuit. For the columns labeled  $b_1$  and  $b_0$ , write the values of these signals as a boolean function of the inputs *up* and *down*, assuming that the values of  $q_0$  and  $q_1$  are as written on that row. You can abbreviate *up* as  $u$  and *down* as  $d$ .

We have filled in the first row as an example:

$q_1$	$q_0$	$q$	$b_1$	$b_0$
F	F	0	$d$	$u \vee d$
F	T			
T	F			
T	T			

- [6] b. For each possible pairs of values of **up** and **down**, this circuit can be seen as computing a function of the input  $q$ . Fill in the following table, indicating the function that is being computed.

up	down	$f(q)$
F	F	$f(q) = q$
F	T	
T	F	
T	T	

- [9] c. Draw the state transition diagram (finite state machine) that corresponds to this circuit. Each state has been labeled with the corresponding value of  $q$  (interpreted as a two's complement signed integer). You need to add the arrows between states. Each arrow should be labeled with a pair of letters that causes this state transition to take place. For instance, we have labeled the one arrow  $01, 11$  to indicate that if the current state is  $0$ , and at the next clock tick we have  $up = 0$  and  $down = 1$ , or  $up = 1$  and  $down = 1$ , then the next state will be  $-1$ .

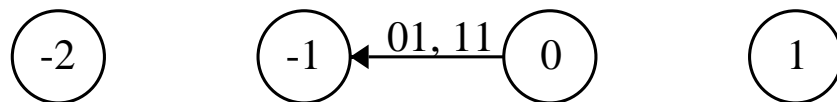

- [3] d. Give a **brief** explanation of what this circuit does. Your answer should be no longer than five simple sentences (shorter answers are possible).

- [8] 6. { **Medium** } Design a DFA that takes as input a string over the alphabet  $\Sigma = \{a, b, c, \dots, z\}$  and ends up in an accepting state if and only if the input string contains *either* the letter **a** followed some time later by the letter **b**, or the letter **c** followed some time later by the letter **d** (or both).

You may write the label **else** on an edge to indicate that the transition will be taken if the next character is any character other than one already used as a label on another edge that starts from the same state (i.e. the same way we did in class for the real numbers example).

- [8] 7. { **Medium** } Prove or disprove the following statements about two functions  $f : B \rightarrow C$  and  $g : A \rightarrow B$ : if  $f$  is one-to-one and  $g$  is onto, then  $f \circ g$  is one-to-one.



[9] 8. { **Medium** } Write regular expressions that describe the following sets of strings:

[3] a. All strings of letters whose first and last characters are both **a**, **or** whose first and last characters are both **o**.

[6] b. All strings over the alphabet  $\{0, 1\}$  that do not contain the substring 011.