

# CPSC 101 2014W: TA Final Exam Practice Package

*\*The difficulty/length of this package may not be representative of the real exam. Please post your questions/concerns on Piazza.*

## Section A: Multiple Choice

- Which best describes how an image is sent over the internet?
  - The image is stored in a packet and sent through the fastest route to reach its destination.
  - The image is stored in a packet and sent through a number of possible routes to reach its destination.
  - The image is broken down into packets which are sent through a number of possible routes to reach their destination, where the image is reconstructed.
  - The image is broken down into packets which are sent through the most direct route to reach its destination, where the image is reconstructed.
- Which of the following is non-permanent?
  - Registers
  - RAM
  - Hard drive/SSD (Solid State Drive)
  - A and B
  - All of the above
- What is BABE (hexadecimal) in binary?
  - 1011 1010 1011 1110
  - 1011 1010 1100 1110
  - 1110 1011 1010 1011
  - 1111 1010 1100 1110
- Which of the following truth tables correctly depicts 'A NAND B'?

a. 

Input		Output
A	B	
0	0	0
0	1	0
1	0	0
1	1	1

b. 

Input		Output
A	B	
0	0	1
0	1	1
1	0	1
1	1	0

c. 

Input		Output
A	B	
0	0	0
0	1	1
1	0	0
1	1	1

d. 

Input		Output
A	B	
0	0	0
0	1	1
1	0	1
1	1	0

5. If 2014 is in the program counter, what will the program counter be after the next Fetch/Decode/Execute/Update cycle assuming the 2014 instruction has no 'branch' or 'jmp' command?
  - a. 2013
  - b. 2010
  - c. 2015
  - d. 2018
  
6. Which of the following most accurately describes the purpose of the Turing Test?
  - a. To determine if a machine is intelligent based on its ability to convince people it is human.
  - b. To determine if a machine is intelligent based on its ability to communicate with humans.
  - c. To determine if a machine is intelligent based on its ability to calculate all possible moves in the imitation game.
  - d. To determine if a machine is intelligent based on its ability to be self-aware.

**Use the below image to answer questions 7 and 8:**



7. The use of this icon to represent the recycling bin (where deleted files go) in the Windows OS is an example of:
  - a. Familiarity and consistency
  - b. Managing complexity
  - c. Well-chosen mapping and metaphors
  - d. Providing useful feedback
  
8. When the recycling bin is emptied, a sound similar to that of paper being thrown away is played. This is an example of:
  - a. Familiarity and consistency
  - b. Managing complexity
  - c. Well-chosen mapping and metaphors
  - d. Providing useful feedback

## Section B: A Blast from the Past

Below is the HTML code and its result (Image 1) from Midterm 1. Alter the code so that the output looks like Image 2. You may use arrows to indicate where you want to insert code- no need to rewrite the entire thing!

Image 1: Original Output

1	2
<ul style="list-style-type: none"> <li>• 3</li> <li>• 4</li> </ul>	<ol style="list-style-type: none"> <li>1. raindrops on roses</li> <li>2. whiskers on kittens</li> </ol>

Image2: New Output

1	2
<ul style="list-style-type: none"> <li>• 3</li> <li>• 4</li> </ul>	<ol style="list-style-type: none"> <li>1. raindrops on roses</li> <li>2. whiskers on kittens</li> </ol>
I love CPSC101	<i>It's a party in the USA!</i>

```

<html>
  <head>
    <title>Nests</title>
  </head>
  <body>
    <table border="1">
      <tr>
        <td>1</td>
        <td>2</td>
      </tr>
      <tr>
        <td>
          <ul>
            <li>3</li>
            <li>4</li>
          </ul>
        </td>
        <td>
          <ol>
            <li>raindrops on roses</li>
            <li>whiskers on kittens</li>
          </ol>
        </td>
      </tr>
    </table>
  </body>
</html>

```

### Section C: Colour Me Purple

1. What colour would be described by **30AC30** (Hexadecimal)? *Hint: Don't need to be too specific.*
  
2. Match the following:  

A. 255, 255, 255	___ White
B. 255, 0, 0	___ Red
C. 0, 0, 0	___ Blue
D. 0, 0, 255	___ Black
  
3. For the values you chose that represent Blue above, how would you alter these values to make the shade lighter and lighter? *Hint: No need to write a function, just describe what you would do to each or all of the values.*
  
4. Answer each of the following: Why is 255 the maximum decimal value we use to describe intensities? Why not 256 or an even larger number like 1024?
  
5. What is a difference between vector and bitmap representation of images? Provide one example of each and explain why your given example is a vector/bitmap.

**Section D: A Day in the Life of a TA**

A student was asked to create a function that takes a number 'n' and returns the product of the numbers from 1 to n. For example, if 4 is used as input, the function will return 24 (which is  $1*2*3*4$ ).

Below is the student's (dysfunctional) code. Fix it up for him/her so that it works as described above.

```
function productN(n) {  
    var prod = 0;  
    var i  
    for(i=1;i <= n;i++) {  
        prod = prod*i;  
    }  
    return prod/n;  
}
```

In the corrected function, what will be the value of i when the return statement is reached if n = 5?

Is the n in function productN(n) a parameter, variable or argument?

## Section E: The Amazing Function

Below is a function, Inform which takes two numerical inputs. Once run, it will print the relationship between the two numbers using a second function, TellMe.

```
function Inform(a,b) {  
    document.write('My analysis reveals that ' + a + TellMe(a,b) + b);  
}
```

For example:

Inform(5,3) will print 'My analysis reveals that 5 is greater than 3.' to the screen.

Inform(2,2) will print 'My analysis reveals that 2 is the same as 2.' to the screen.

Inform(1,99) will print 'My analysis reveals that 1 is less than 99.' to the screen.

And so forth. Write the TellMe function which functions as described above. The first line of code has been provided:

```
function TellMe(x,y)  {
```

What is the difference between a return statement and a document.write statement in Javascript?  
Which one should be used by the TellMe function and why?

**Section F: You are the chosen one, Neo**

Below is the state of memory *prior* to the execution of any instructions.

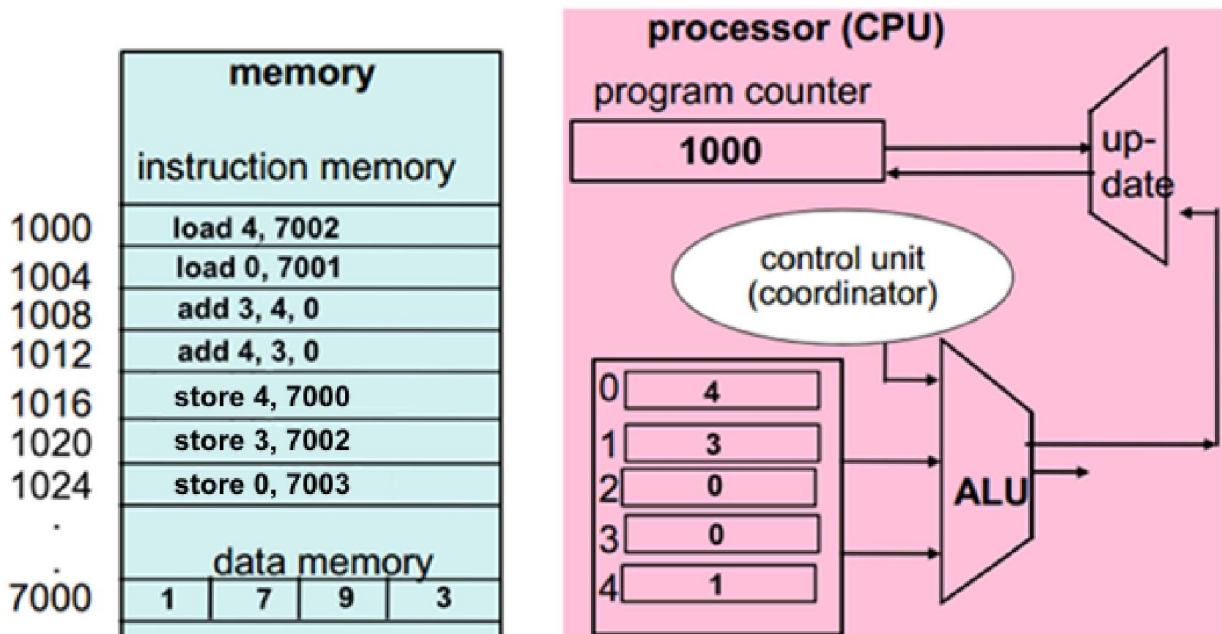

Based on this initial state, describe the state of the memory *after* the Fetch, Decode, Execute and Update cycle of the final instruction (instruction memory 1024).

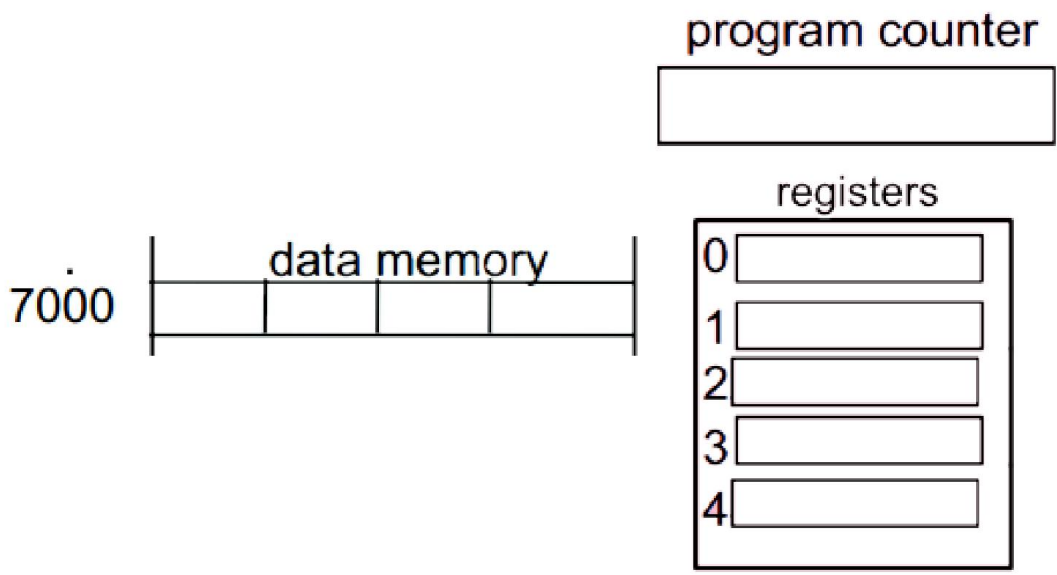

**Section G: Hold the gates**

Given the following gating schemes and inputs A and B, determine the output at the end. **Show your work.**

1. If  $A = 1$  and  $B = 1$ , what is X?

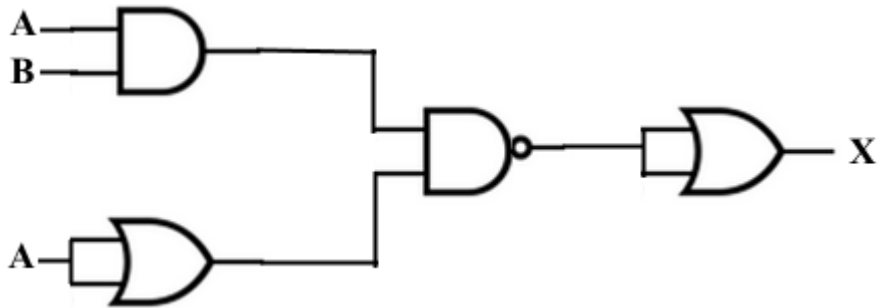

2. If  $A = 0$  and  $B = 1$ , what is Y?

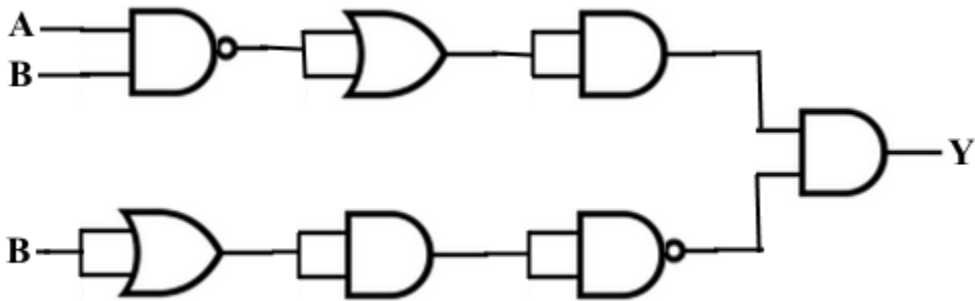

3. If both  $A$  and  $B = 0$ , what is Z?

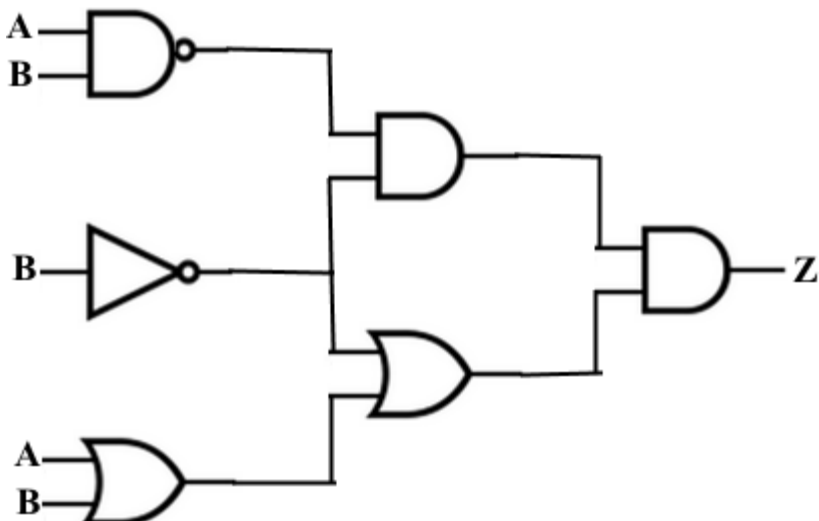



**Section H: Gaga for TSP**

Construct the TSP input corresponding to the FAP input below:

**AGAGT, TAGA, GAGA and CGCG**

Perform the TSP procedure to determine the most efficient solution and list its order of assembly. What is the cost of your solution? **Show all your work.**

**End of Practice Package: Good Luck! ☺**